



Ice Cream Freezer

IC352D



Item number	23424310000IC352D	Taric goods code	8418501190
EAN code	5704704019546	QTY in 40HQ	81

Short Description

Freezer function from -18°C to -24°C with Intelligent air circulation system, which ensures uniform ventilated cold distribution throughout the freezer. As a freezer display case, it is ideal for storing ice cream.

5 strong wire baskets with 2 partitions in each are included.

The freezer has 4 wheels and is easy to move around, even if it is full. The design is top class with soft and round corners.

The ice cream freezer comes with curved transparent sliding lids with an integrated handle that keeps the cold extra.

Key features

- Curved sliding glass lids with lock
- 5 strong wire baskets including 2 dividers in each
- Coated white steel inner liner
- 4 strong castors
- Suitable for branding

Measurement Drawings

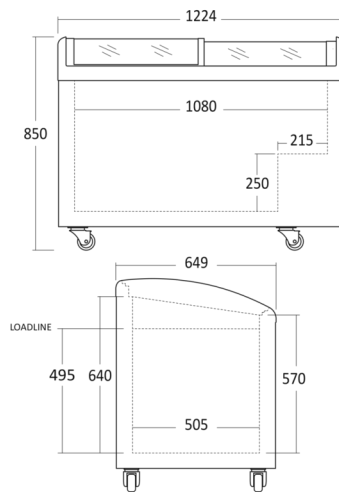

Dimensions and weight

Product dimensions, HxWxD, mm	850 x 1240 x 649
Product depth w/handle, mm	649
Packaging dimensions, HxWxD, mm	895 x 1310 x 735
Gross volume, L	330
Net volume, L	251
Gross- / Net volume, L	330 / 251
Internal dimensions, HxWxD, mm	640 x 1080 x 505
Gross- / Net weight, kg	79 / 68

Performance and consumption

Energy efficiency class	D
Daily Energy Consumption, kWh/24	1,86
Annual energy cons. kWh/a	680
Energy Efficiency Index (EEI)	41,54
Noise level, dB(A)	70
Refrigeration / freezing technique	Static
Climate class	7
Temperature class	C1
Type of refrigerant / gas gr.	R290a / 80
Temperature range °C	-18 / -24
NoFrost	No

Installation and power

Voltage / hertz, V/hz	230 / 50
Peak power watt, W	280
Watt / Ampere, W/A	180 / 2.2
Length of Powercord, cm	200

Design and comfort

Controller	Mechanical
Control panel	Outside
Digital display	No
Internal light	No light
External thermometer	Yes
Door- / lid type	Sliding
Handle	Integrated
Number of castors, pcs	4 castors (2 w/brake)
Lock & Key	Yes

Colour and material

Outside colour	White
Inside Colour	White
Colour and material of door/lid	Sliding glass

Features

Number of baskets, pcs	5
Basket Size (HxWxD) (mm)	Yes
Max loading per shelf/basket, kg	20

scandomestic

Scandomestic A/S . Linåvej 20 . DK-8600 Silkeborg . Tel.: +45 7242 5571 . www.scandomestic.dk